

# CopperLink™ Model 1101E/IP67 Outdoor Rated Power over Ethernet Extender

---

## Quick Start Guide



**Important**—This is a Class A device and is intended for use in a light industrial environment. It is not intended nor approved for use in an industrial or residential environment.



**WARNING**

- This device contains no user serviceable parts. The equipment shall be returned to Patton Electronics for repairs, or repaired by qualified service personnel.
- The external power adapter shall be a listed Limited Power Source. The mains outlet that is utilized to power the device shall be within 10 feet (3 meters) of the device, shall be easily accessible, and protected by a circuit breaker.
- If an AC power adapter is used, ensure that the power cable used meets all applicable standards for the country in which it is to be installed, and that it is connected to a wall outlet which has earth ground.
- Hazardous network voltages are present in WAN ports regardless of whether power to the unit is ON or OFF. To avoid electric shock, use caution when near WAN ports. When detaching the cables, detach the end away from the device first.
- Do not work on the system or connect or disconnect cables during periods of lightning activity.



**CAUTION**

#### **SPECIAL CONDITION FOR SAFE USE**

**Ambient temperature:** This unit is designed for use in extreme ambient temperature: -14 to 158°F (-10 to 70°C).

**Restricted Access:** The surface of this unit can exceed 100°C under extreme ambient conditions and should be installed in restricted locations only.

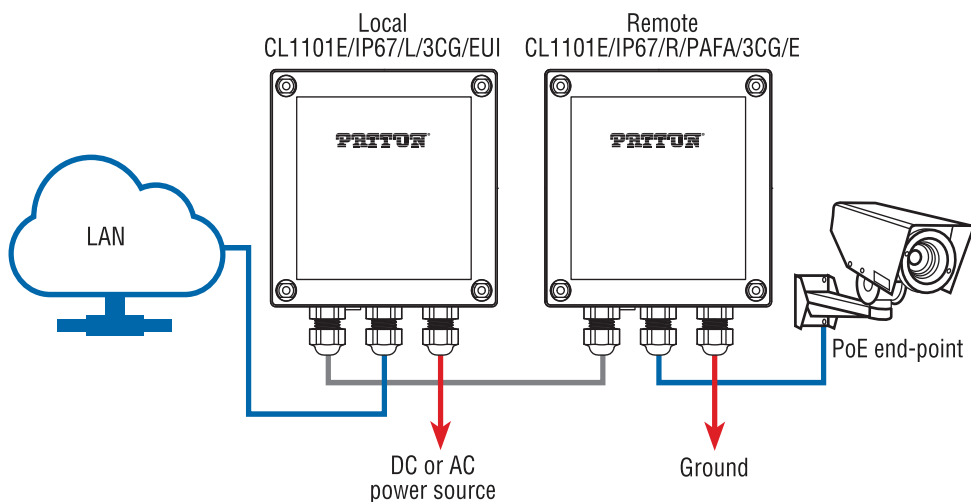
---

## 1.0 Introduction

---

The CopperLink Model 1101E/IP67 is an Outdoor Rated Ethernet Extender. The CL1101E/IP67, works in pairs (one Local CL1101E/IP67 to one Remote CL1101E/IP67) to extend Ethernet over twisted pair or Coax. The Local unit resides where a power source is available, the Remote unit resides by the PoE end point. All CL1101E/IP67 models are interoperable with each other. For example: a CL1101E/IP67 (indoor) local unit can connect to a CL1101E/IP67 (remote). In fact, this would be a typical use case.

The CopperLink Model 1101E/IP67 is IP67 rated. This means that it meets level 6 for solid object protection (dust proof) and level 7 for liquid ingress (can be fully submersed at water 15 cm to 1 m deep for a period of up to 30 minutes).



**Figure 1.** CL1101E/IP67 Ethernet Extender application

If you will be installing a Local CL1101E/IP67, go to section 2.0 “**Planning the Local CL1101E/IP67 Installation**” on page 4. Otherwise, to install a Remote CL1101E/IP67, go to section 3.0 “**Planning the Remote CL1101E/IP67 Installation**” on page 5.

---

## 2.0 Planning the Local CL1101E/IP67 Installation

---

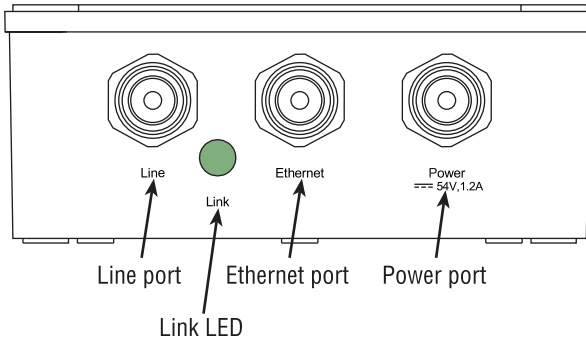


The interconnecting cables shall be acceptable for external use and shall be rated for the proper application with respect to voltage, current, anticipated temperature, flammability, and mechanical serviceability.



To maintain IP67 performance, the cable glands provided on our standard unit are for wire diameters ranging from 0.157 inch [4 mm] to 0.252 inch [6.4 mm]. If your cables do not fit these specifications, contact [support@patton.com](mailto:support@patton.com) before using them outdoors.

To install the Local CL1101E/IP67 Ethernet Extender (see **figure 2**), do the following:



**Figure 2.** Local CL1101E/IP67 LED and ports

1. Connect a data & power cable to the *Line* interface (see section 4.0 “Connecting the Line Interface” on page 6).
2. Connect an Ethernet cable to the *Ethernet* interface (see section 5.0 “Connecting the 10/100Base-T Ethernet Interface” on page 8).
3. Connect the power supply cable to the *Power* port (see section 7.0 “Connecting power to the Local unit” on page 10).
4. Configuring the DIP switch (see section 8.0 “Configuring the DIP Switch” on page 11).

## 3.0 Planning the Remote CL1101E/IP67 Installation

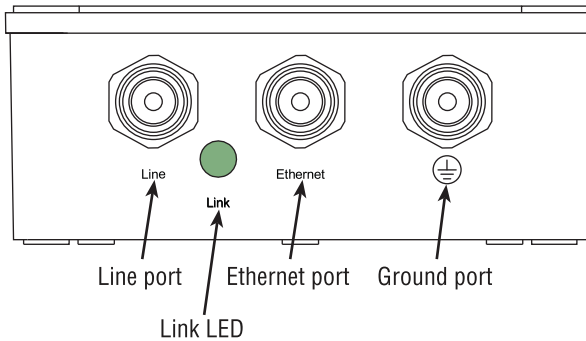


The interconnecting cables shall be acceptable for external use and shall be rated for the proper application with respect to voltage, current, anticipated temperature, flammability, and mechanical serviceability.



To maintain IP67 performance, the cable glands provided on our standard unit are for wire diameters ranging from 0.157 inch [4 mm] to 0.252 inch [6.4 mm]. If your cables do not fit these specifications, contact [support@patton.com](mailto:support@patton.com) before using them outdoors.

To install the Remote CL1101E/IP67 Ethernet Extender (see **figure 3**), do the following:



**Figure 3.** Remote CL1101E/IP67 LED and ports

1. Connect a data & power cable to the *Line* interface (see section 4.0 “Connecting the Line Interface” on page 6).
2. Connect an Ethernet cable to the *Ethernet* interface (see section 5.0 “Connecting the 10/100Base-T Ethernet Interface” on page 8).
3. Connect a ground wire to the grounding screw (see section 6.0 “Connecting to the grounding screw on the Remote unit” on page 10).
4. Configuring the DIP switch (see section 8.0 “Configuring the DIP Switch” on page 11).

---

## 4.0 Connecting the Line Interface

---



CAUTION

The interconnecting cables shall be acceptable for external use and shall be rated for the proper application with respect to voltage, current, anticipated temperature, flammability, and mechanical serviceability.

**Note** The CL1101E/IP67 Ethernet Extenders work in pairs (a Local unit connects to a Remote unit).

**Note** Actual distance and link performance may vary depending on the environment and type/gauge of wire used.



IMPORTANT

Power is **NOT** transmitted as on traditional PoE. PoE pin-out assumes that the same polarity is on a single pair of wires, but in order to accommodate 1 pair mode, the polarity is alternated within the pair.

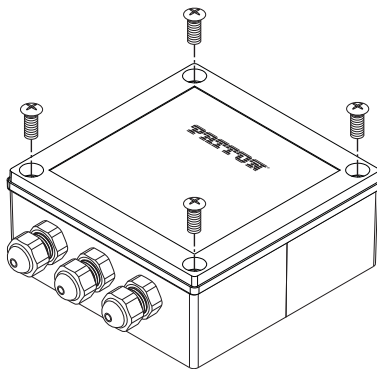


CAUTION

Never connect the Line interface to a PoE port because equipment damage may occur.

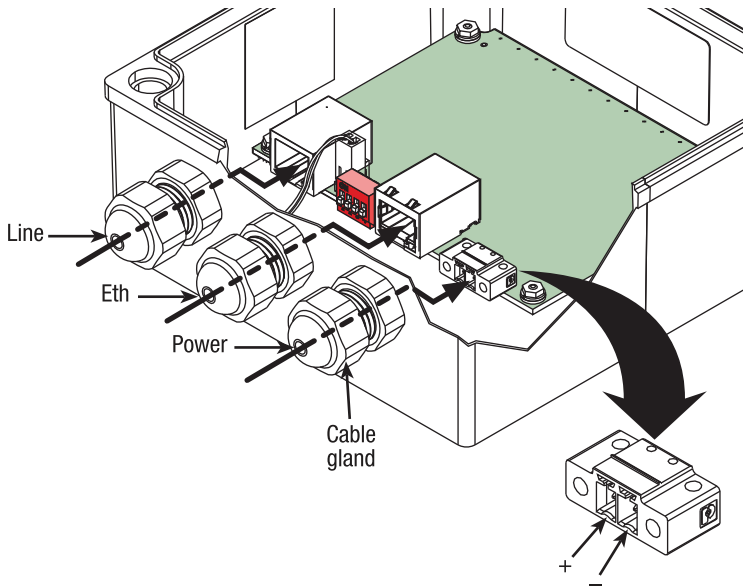
Do the following to connect the *Line* interface.

1. Remove the top panel screws by turning them counter-clockwise (see **Figure 4**. “Removing the top cover” on page 6).

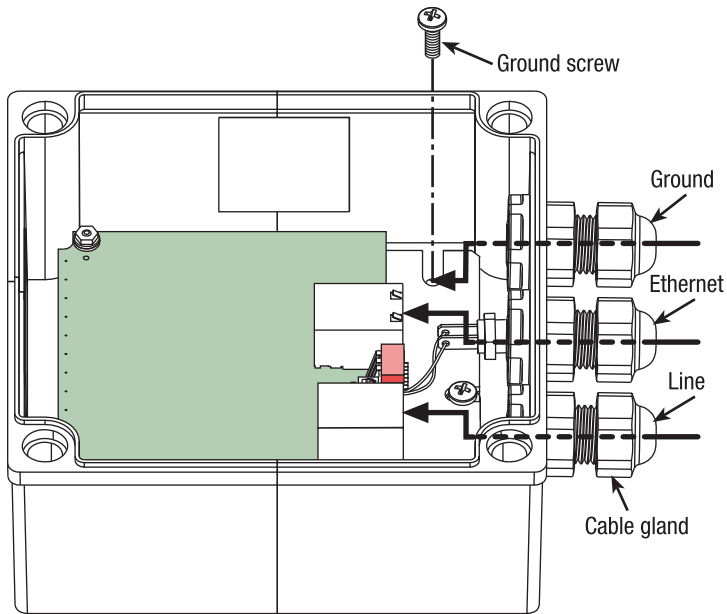


**Figure 4.** Removing the top cover

2. Loosen the IP67 cable glands by turning them counter clockwise. (For the Local unit, see **figure 5** on page 7. For the Remote unit, see **figure 6** on page 7).



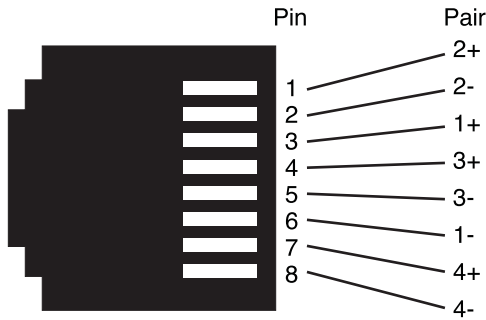
**Figure 5.** Local unit cable glands



**Figure 6.** Remote unit cable glands

3. Run an un-terminated data/line cable through the gland labeled *Line*.

- The CL1101E/IP67 is equipped with an RJ-45 interface jack. Terminate the cable with an RJ-45 connector (see **figure 7** for pin-out diagram).



**Figure 7.** RJ-45 pin-out

- The RJ-45 connector on the CL1101E/IP67’s twisted pair interface is polarity insensitive, and is wired for two, four, six or eight wires—pin-out to TIA/EIA T568A/B (see **table 1** on page 8).

**Table 1.** RJ-45 wire modes

Pair	Pin	Voltage
1+	3	+
1-	6	-
2+	1	+
2-	2	-
3+	4	+
3-	5	-
4+	7	+
4-	8	-

**Note** **2-wire mode**—non-standard pin-out  
**4-wire mode**—802.3i/802.3u wired compatible pin-out  
**8-wire mode**—802.3ab/802.3an wired compatible pin-out

---

## 5.0 Connecting the 10/100Base-T Ethernet Interface

---

Do the following to connect the 10/100Base-T *Ethernet* interface:

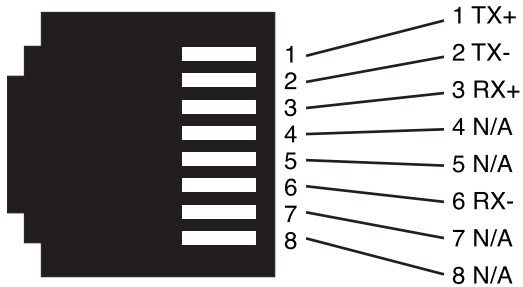
- Run an un-terminated Ethernet cable through the gland marked *Ethernet*.
- Terminate the cable with an RJ-45 connector. The RJ-45 *Ethernet* port is an Auto-MDIX 10/100Base-T that connects to a 10/100Base-T device or network. **Figure 8**



on page 9 shows the signal/pin relationships on this interface. You may connect this port to a hub or PC using a straight-through or crossover cable (see Appendix 2 on page 9) that is up to 328 ft long.



The interconnecting cables shall be acceptable for external use and shall be rated for the proper application with respect to voltage, current, anticipated temperature, flammability, and mechanical serviceability.



**Figure 8.** CL1101E/IP67 10/100Base-T RJ-45 Connector Pin-out

Table 2. RJ-45 wire modes

Pin	Voltage	Function
1	Mode A +	Tx +
2	Mode A +	Tx -
3	Mode A -	Rx +
4	Mode B +*	N/A
5	Mode B +*	N/A
6	Mode A -	Rx -
7	Mode B -*	N/A
8	Mode B -*	N/A

**Note** Mode A and Mode B are not configurable, the remote unit requires different hardware.

For Mode A order:

- CL1101/PAFA/x/EUI-2PK (Ethernet Extender Kit)
- CL1101/PAFA/x/EUI (Remote PoE Extender)

For Mode B order:

- CL1101/PAFB/x/EUI-2PK (Ethernet Extender Kit)
- CL1101/PAFB/x/EUI (Remote PoE Extender)

---

## 6.0 Connecting to the grounding screw on the Remote unit

---

As a standard safety practice, the chassis of the CL1101E/IP67 must be properly grounded to protect against any contact with an electrical fault condition.

Do the following to connect to the CL1101E/IP67 to ground:

1. Run an un-terminated ground cable through the gland labeled with a ground symbol (see **figure 3** on page 5).
2. Terminate the cable with the spade lug provided with the unit or your own terminal.
3. Remove the grounding screw (see **figure 6** on page 7).
4. Attach the ground cable to the steel plate using the grounding screw.
5. Connect the other end of the ground wire to an electrical ground nearest the CL1101E/IP67. Often this will be on an electrical panel or sub panel. If you cannot locate a nearby electrical ground, contact Patton Technical Support at (301) 975-1000 to discuss an alternative grounding solution.

**Note** Keep the length of the ground wire as short as possible.

6. Verify that the resistance of the ground path is less than 0.5 ohms.

---

## 7.0 Connecting power to the Local unit

---



**CAUTION**

The interconnecting cables shall be acceptable for external use and shall be rated for the proper application with respect to voltage, current, anticipated temperature, flammability, and mechanical serviceability.

**Note** The Local CL1101E/IP67 does not have a power switch, so it powers up as soon as it is connected to a power source.

An external AC to DC adapter is supplied with the units. No configuration is necessary for the power supply.

**Note** DC power must meet the following requirements; DC power supplied must be regulated 12 VDC  $\pm 5\%$  to 54 VDC  $\pm 5\%$ .

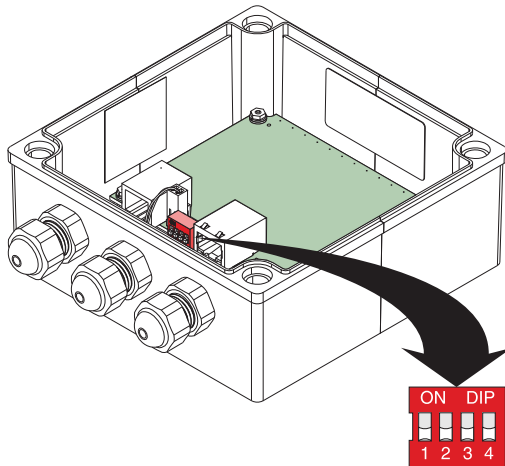
Do the following to connect the power cable to the Local unit:

1. Run an un-terminated power cable through the gland labeled *Power* (see **figure 5** on page 7).
2. Connect the cable wires to the terminal block shown in **figure 5**. Be sure to match the cable wires polarity with that of the terminal block.

**Note** A power supply can be installed on the remote unit even if the unit is receiving power across the line.

## 8.0 Configuring the DIP Switch

DIP switch (see **figure 9**) settings are described in **table 3**.



**Figure 9.** 4-position DIP switch

**Table 3.** DIP switch settings

Switch (left to right) Function	1	2	3	4
	Down: 100 Mb, Up: 10 Mb	Down Down: 2-wire mode Down Up or Up Down: 4-wire mode Up Up: 8-wire mode*		Remote only** Up: Legacy PoE mode Down: IEEE802.3af PoE

\*8-wire mode 10 Mb not supported, will default to 10 Mb 4-wire mode

\*\*Switch has no function on Local unit

---

## 9.0 Customer and Technical Support

---

Toll-Free VoIP support: call [sip:support@patton.com](tel:sip:support@patton.com) with a VoIP SIP phone

Online support: [www.patton.com](http://www.patton.com)

E-mail support: [support@patton.com](mailto:support@patton.com)—answered within 1 business day

Telephone support:

<b>Standard</b>	USA	+1 (301) 975-1007	Monday - Friday	8:00 am to 5:00 pm EST (1300 to 2200 UTC/GMT)
<b>Alternate</b>	Switzerland	+41 (0)31-985-2555	Monday - Friday	8:00 am - 5:00 pm CET (0900 to 1800 UTC/GMT)